

INSTRUCTION MANUAL

Orion® Paragon-Plus™ Binocular Mount

#5379 with tripod, #5376 tripod not included

Français

① Pour obtenir le manuel d'utilisation complet, veuillez vous rendre sur le site Web OrionTelescopes.eu/fr et saisir la référence du produit dans la barre de recherche.

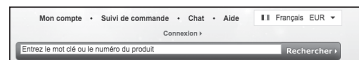

② Cliquez ensuite sur le lien du manuel d'utilisation du produit sur la page de description du produit.

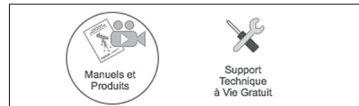

Deutsche

① Wenn Sie das vollständige Handbuch einsehen möchten, wechseln Sie zu OrionTelescopes.de, und geben Sie in der Suchleiste die Artikelnummer der Orion-Kamera ein.

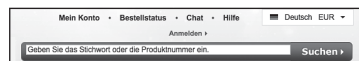

② Klicken Sie anschließend auf der Seite mit den Produktdetails auf den Link des entsprechenden Produkthandbuchs.



Español

① Para ver el manual completo, visite OrionTelescopes.eu y escriba el número de artículo del producto en la barra de búsqueda.



② A continuación, haga clic en el enlace al manual del producto de la página de detalle del producto.

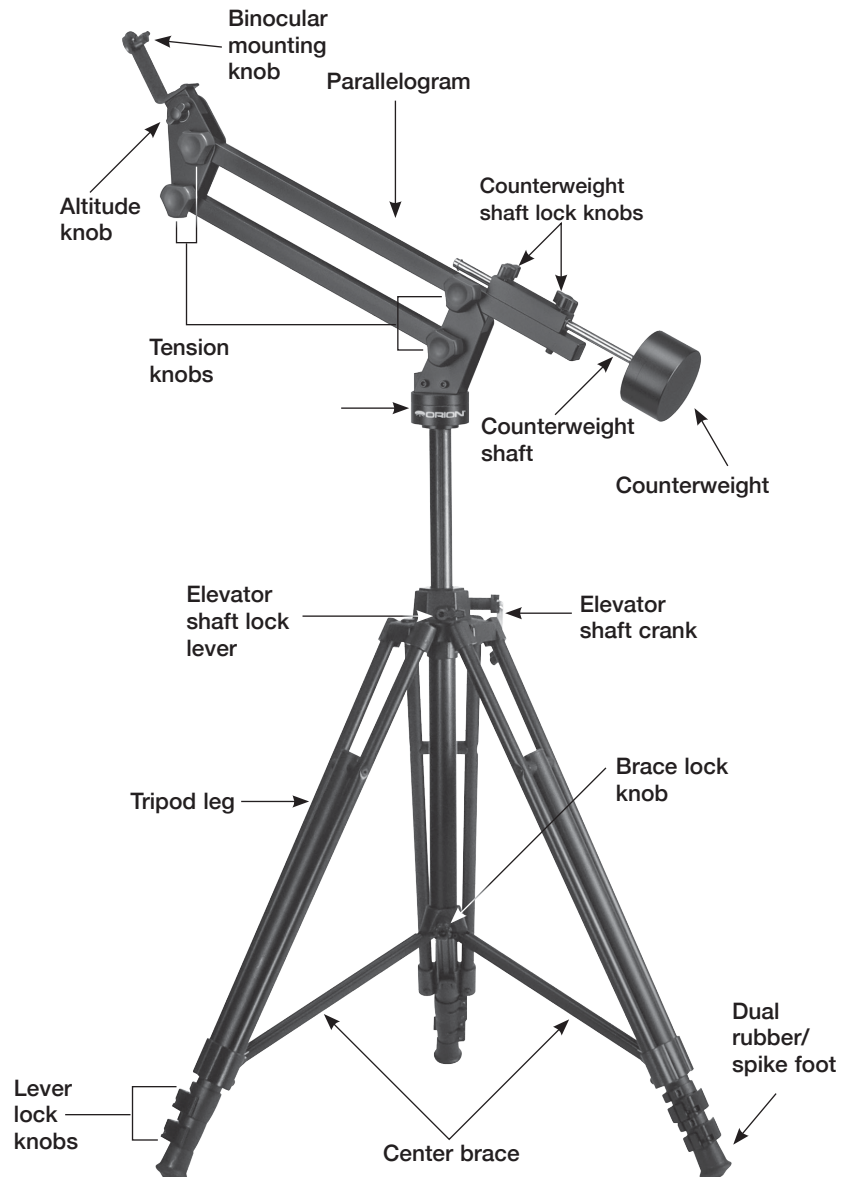

Figure 1. The Paragon-Plus binocular mount



Corporate Offices: 89 Hangar Way, Watsonville CA 95076 - USA
Toll Free USA & Canada: (800) 447-1001
International: +1(831) 763-7000
Customer Support: support@telescope.com

Copyright © 2020 Orion Telescopes & Binoculars. All Rights Reserved. No part of this product instruction or any of its contents may be reproduced, copied, modified or adapted, without the prior written consent of Orion Telescopes & Binoculars.



Figure 2. Line up the threaded pan head attachment shaft of the tripod with the threaded hole on the bottom of the pivot disk. Then hold the binocular mount still while turning the pivot disk to thread it onto the shaft.

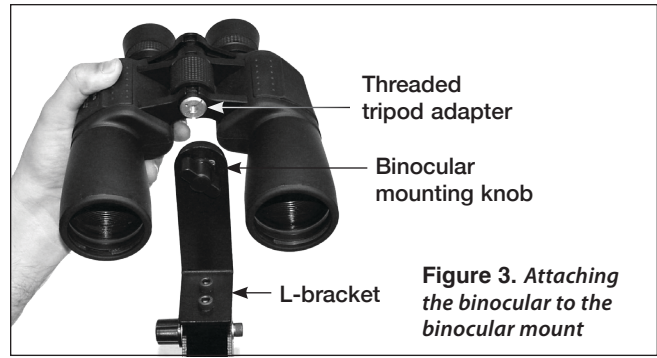

Figure 3. Attaching the binocular to the binocular mount

Congratulations on your purchase of the Orion Paragon-Plus Binocular Mount. This sturdy support apparatus is designed to allow comfortable use of binoculars up to 80mm in aperture for astronomical or terrestrial viewing. The mount greatly reduces arm strain and positions the binocular away from the tripod, allowing the viewer to stand or sit comfortably under the binocular while aiming it overhead — even to the zenith. The mount also enables the binocular to be raised and lowered while still staying right on a given target, a wonderful feature when two or more people of different heights are observing together.

These instructions cover assembly and use of both the Paragon-Plus Binocular Mount only (#5376, without tripod) and the Paragon-Plus Binocular Mount & Tripod (#5379). Please read them thoroughly.

Attaching the Paragon-Plus Binocular Mount to a Tripod

The attachment instructions cover the attachment to either the Paragon-Plus tripod (included with #5379), or any sturdy tripod you might already have. You will need a flat-head screwdriver and a 2mm hex wrench to attach the binocular mount to a tripod. Refer to Figure 1 during assembly.

- 1) Remove the pan head of the tripod you plan to use. If you purchased the Paragon-Plus binocular mount and tripod, you will not need to do this as the tripod does not come with a pan head. Note the size of the screw the tripod uses to attach the pan head.
- 2) Turn the binocular mount upside down. On the bottom of the pivot disk (Figure 1) there is a 3/8" threaded hole containing a brass 1/4"-20 threaded insert. This may need to be removed, depending on the tripod you are using. Compare the size of the threaded post on the tripod with the size of the brass insert. If the brass insert is too small, then it will need to be removed. It should be removed to use it with the Paragon-Plus tripod in the #5379 package. Use the flat-head screwdriver to do this.
- 3) Spread the legs of the tripod as far as they will go and lock them in place with the brace lock knob (Figure 1). Keep the legs at their shortest height, for now. The Paragon-Plus tripod has a very wide stance for enhanced stability. The widest stance is achieved when the tri-brace is as far down as it will go on the elevator shaft housing. The brace lock knob should be tightened to secure the stance. When using the binocular mount, the tripod legs

should always be fully extended, otherwise the weight of the binocular mount could cause the tripod to tip over.

- 4) For the Paragon-Plus tripod, attach the parallelogram mount to the platform on top of the elevator shaft (Figure 2). For other tripods, thread the mount onto the shaft where the pan head normally goes. Do this by placing the hole on the bottom of the mount onto the shaft while holding the mount with one hand. With your other hand, turn the pivot disk until it is tight.
- 5) If you are using the Paragon tripod, you secure the pivot disk to the platform on top of the elevator shaft with the setscrews located underneath the platform. With the 2mm hex wrench, thread the setscrews until they are secure. The mount should now be able to pivot without unthreading from the tripod.

Your Paragon-Plus binocular mount is now assembled and should resemble Figure 1.

Attaching the Binocular to the Binocular Mount

The Paragon-Plus binocular mount is capable of holding binoculars of up to 80mm aperture. The binocular must have a threaded socket for mounting. Adjust the tripod height to the level you will be viewing from before mounting the binoculars. See below for instructions on how to raise the Paragon-Plus tripod.

Remove the cover cap from the threaded tripod adapter on your binocular. Then thread the binocular mounting knob into the tripod adapter on the binocular until it is secure (Figure 3). Please note that if you are using a large binocular that employs a central support shaft (such as the Orion MegaView), then you will need an optional mounting plate (#7589).

Balancing the Paragon-Plus Binocular Mount

To assure smooth movement of the binocular mount, the binocular should be properly balanced on the mount by adjusting the counterweight shaft. Note that a perfect balance is not necessary, as the balance can be compensated by using the tension knobs. However, try to achieve as precise a balance as possible.

- 1) Loosen all four tension knobs and carefully bring the mount to a horizontal position.
- 2) Loosen the counterweight shaft knobs and slide the counterweight shaft out from the mount until it balances the binocular on the other end. Note that a perfect bal-

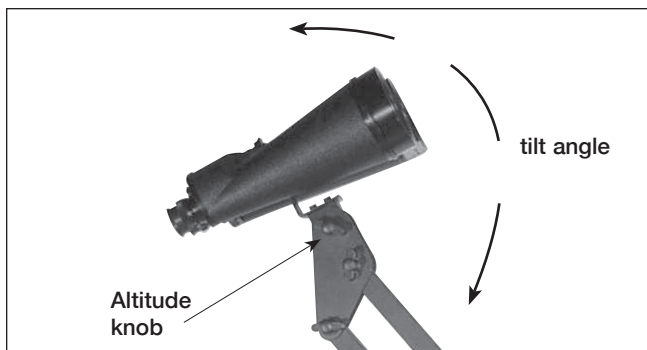

Figure 4. The “tilt angle” of the binoculars

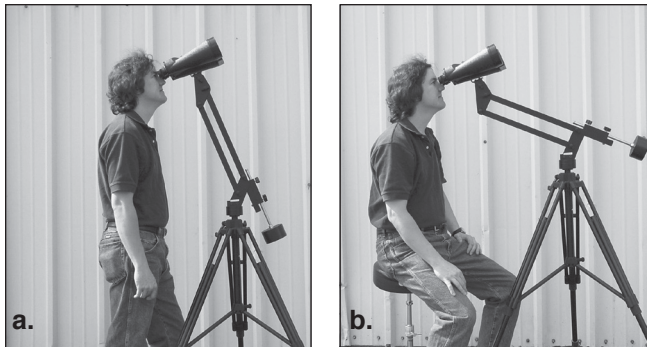

Figure 5. The binocular will remain on target as you adjust the height using the parallelogram. The standing person in (a) is looking at the same thing while seated in (b). Note that only the parallelogram has moved; the tilt angle of the binocular has not. The pivot disk and binocular altitude should not be adjusted for this feature to work.

ance may not be achievable with a very light or very heavy binocular.

If the mount will not balance (very likely with a small binocular), you can make adjustments to the tension knobs until the mount remains in place when you stop moving it. If it does not, increase the tension with the tension knobs.

Adjusting the “Tilt Angle” of the Binocular

The binocular “tilt angle” is controlled with the altitude knob (Figure 4). You should set the knob tension such that the binocular will move when pushed, but will not move on its own. Keep in mind that as the angle of the binocular approaches the zenith, the knob tension will need to be increased so that the binocular does not flop over. Increase the knob tension when bringing the binocular 40° or more from horizontal.

Adjusting Azimuth

Moving the binocular in azimuth (left/right) is a simple matter of turning the mount on its pivot disk. There is no azimuth lock feature.

Adjusting the Height of the Binocular

A nice feature of the Paragon-Plus binocular mount is that when the binocular is pointed at an object, the height can be adjusted for different viewers without moving the binocular off its target. To do this, simply move the binocular so that only the parallelogram part of the mount is moving. Do not adjust the tilt angle of the binocular or move the mount on



Figure 6. The binocular mount can be used to view objects at or near the zenith. Adjust the tripod so that you can stand under the binocular to view objects located high in the sky.

its pivot disk. Figure 5 shows this feature in action. Using this feature, people of varying heights will be able to enjoy binocular views without any crouching over or straining to reach the binocular.

Adjusting the Paragon-Plus Tripod Height (#5379)

You may find that the binocular position is too low when the tripod legs are fully retracted. To raise the height you should extend the legs of the tripod. You should remove the binocular mount before extending the tripod legs to prevent the mount and tripod from falling over.

Each leg of the tripod has two telescoping sections. To extend a leg, loosen the lever lock knob, then extend the leg. When it has been extended to the desired length, tighten the lever knob back down. There is a handy scale printed on the middle segment of each leg, which can be used to judge the relative height of the legs.

Although the Paragon-Plus tripod also has an elevator shaft, this should be used with the binocular mount only after raising the tripod by use of the legs. Extending the elevator shaft reduces the stability of the binocular mount. To operate the elevator shaft, loosen the elevator lock knob and turn the elevator hand crank to adjust to the desired height. Then tighten the elevator lock knob.

Dual Rubber/Spike Feet (#5379)

The tripod is equipped with dual-purpose feet that consist of a retractable rubber foot and a metal spike. The rubber feet are intended for use of the tripod indoors or on a smooth, paved surface. The metal spikes are desirable for achieving a firm grip on soft surfaces. To use the rubber feet, thread the foot counterclockwise until it stops. In this position, the metal spike will be well recessed within the rubber. Be sure all three rubber feet are flat on the floor, not tipped sideways.

To expose the spike feet, thread the rubber foot clockwise until the spike protrudes from the rubber. In some instances you may wish to remove the rubber feet altogether so more of the metal spike is exposed. This can be done by pulling the rubber feet off their anchors. They can be pressed on again at any time.

Parallelogram Safety Stop

The parallelogram has a safety stop to prevent the aluminum bars from completely collapsing. This ensures that no fingers will be caught and crushed by an accidental fast closing of the parallelogram. This feature will also prevent the counterweight from hitting the tripod.

Astronomical Use

The Paragon-Plus binocular mount allows viewing of subjects from the horizon all the way up to the zenith. To view objects at the zenith, adjust the binocular mount and tripod so that they will be tall enough for you to stand underneath the binocular. Then adjust the tilt angle of the binocular to point it at the zenith. Stand underneath the binocular and look up into them. When done properly, this should resemble Figure 6.

Transporting

When moving the binocular mount any significant distance, you should remove the binocular to prevent them from being damaged. To make moving easier, you may want to separate the mount from the tripod. An optional carrying case (#15161) is also available from Orion to make transportation easier.

Care and Maintenance

When using the mount in direct sunlight, be aware that its black surface can become hot. If the mount is used in wet conditions, dry it completely with a soft cloth after use. Clean the tripod and mount with a mild detergent and a soft cloth.

Specifications

Maximum binocular weight:	5.5 lbs.
Counterweight:	8 lbs.
Binocular mounting knob:	Accommodates Binocular with 1/4"-20 tripod adapter
Minimum binocular height (with Paragon-Plus tripod):	31"
Maximum binocular height (with Paragon-Plus tripod):	91"
Weight (without Paragon-Plus tripod):	12 lbs. 9 oz.
Weight (With Paragon-Plus tripod):	19 lbs. 10 oz.
Carry case:	Optional

One-Year Limited Warranty

This Orion product is warranted against defects in materials or workmanship for a period of one year from the date of purchase. This warranty is for the benefit of the original retail purchaser only. During this warranty period Orion Telescopes & Binoculars will repair or replace, at Orion's option, any warranted instrument that proves to be defective, provided it is returned postage paid. Proof of purchase (such as a copy of the original receipt) is required. This warranty is only valid in the country of purchase.

This warranty does not apply if, in Orion's judgment, the instrument has been abused, mishandled, or modified, nor does it apply to normal wear and tear. This warranty gives you specific legal rights. It is not intended to remove or restrict your other legal rights under applicable local consumer law; your state or national statutory consumer rights governing the sale of consumer goods remain fully applicable.

For further warranty information, please visit www.OrionTelescopes.com/warranty.



Corporate Offices: 89 Hangar Way, Watsonville CA 95076 - USA
Toll Free USA & Canada: (800) 447-1001
International: +1(831) 763-7000
Customer Support: support@telescope.com

Copyright © 2020 Orion Telescopes & Binoculars. All Rights Reserved. No part of this product instruction or any of its contents may be reproduced, copied, modified or adapted, without the prior written consent of Orion Telescopes & Binoculars.