

INSTRUCTION MANUAL

Orion® Truss Tube Ritchey-Chrétien Astrographs

51874 10" TTRC ◦ 51875 12" TTRC ◦ 52713 14" TTRC ◦ 52714 16" TTRC

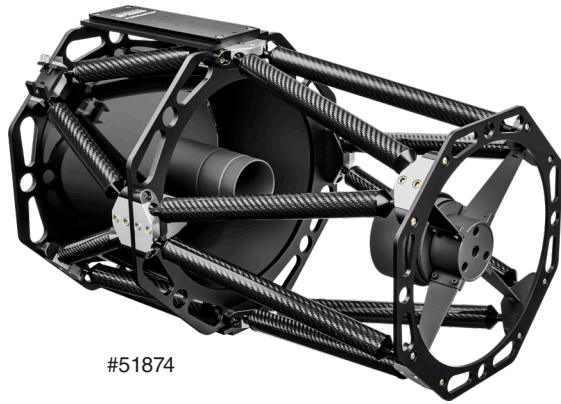

#51874

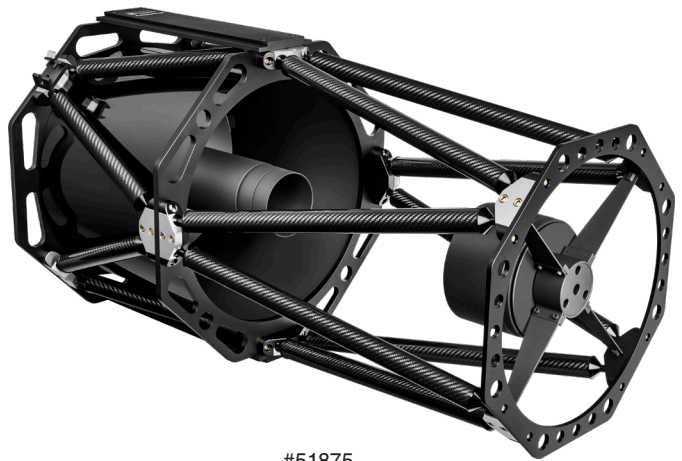

#51875

#52713



 **ORION**®
TELESCOPES & BINOCULARS
AN EMPLOYEE-OWNED COMPANY

Corporate Offices: 89 Hangar Way, Watsonville CA 95076 - USA
Toll Free USA & Canada: (800) 447-1001
International: +1(831) 763-7000
Customer Support: support@telescope.com

Copyright © 2022 Orion Telescopes & Binoculars. All Rights Reserved. No part of this product instruction or any of its contents may be reproduced, copied, modified or adapted, without the prior written consent of Orion Telescopes & Binoculars.

Congratulations on your purchase of an Orion Truss Tube Ritchey-Chretien Astrograph (TTRC). These compact but large-aperture telescopes are designed and optimized for high-performance astrophotography with CCD and DSLR cameras. Sporting an optical design comprising hyperbolic primary and secondary mirrors, the RC is highly regarded by advanced astrophotographers and professional observatories worldwide. Even the vaunted Hubble Space Telescope is a Ritchey-Chretien. Orion TTRCs deliver exceptional image quality and resolution with zero image shift and minimal coma. Either one of these superb instruments, when paired with a solid mount, will take your imaging pursuits to a whole new and very exciting level.

Unpacking Your Telescope

Use care when unpacking the shipping carton. We recommend keeping the box and all original packaging materials. In the event that the telescope needs to be shipped to another location, or returned for warranty repair, having the proper packaging will ensure that your telescope will survive the journey intact. Returns for refund or exchange will not be accepted without all of the original packaging. Make sure that all the items listed in the Parts List below are present.

Parts List

QTY	ITEM
1	Truss Tube RC optical tube assembly
1	2" Extension ring
2	1" Extension rings
1	Secondary mirror dust cover
1	Primary mirror dust cover
1	Battery holder (for fans)

Warning: Never look directly at the Sun through your telescope—even for an instant—without a professionally made solar filter that completely covers the front of the instrument, or permanent eye damage could result. Young children should use this telescope only with adult supervision.

Truss Tube Design

Orion TTRC telescopes feature a Serrurier truss design -- the same truss configuration as the 200-inch Hale telescope at the Palomar Observatory! Developed by engineer Mark U. Serrurier in 1935 specifically for the Hale telescope, this design utilizes two sets of opposing truss tubes on either side of the declination pivot plane. The trusses are designed to effect an equal amount of flexure, which allows the optics to stay on a common optical axis. When flexing, the "upper" truss resists tension and the "lower" truss resists compression. This keeps the optical elements parallel to each other no matter how the telescope is oriented, thus keeping optical collimation precisely intact.

The truss tubes in the Orion TTRC telescopes are made of a carbon fiber-reinforced composite material with a very low thermal expansion profile. Stainless steel ball and socket hardware connects the truss tubes to the telescope's three large CNC-machined aluminum support plates.

The truss design of the optical tube is of course an open tube design. While both the primary and secondary mirrors are recessed within baffled cylindrical housings, it is still possible that ambient light from one's observing or imaging location could have an adverse effect on image contrast. It's best to use these telescopes at a truly dark site to avoid such intrusions. If necessary, however, you should consider making or purchasing an opaque fabric "shroud" to cover the tube assembly between the front and rear plates. A shroud will block stray light from entering the optical path as well as help to prevent dew formation on the mirrors.

The 3" Linear Bearing Crayford Focuser

Orion TTRC telescopes come standard with a CNC-machined, 3" dual-speed (10:1) linear bearing Crayford focuser (**Figure 1**). The linear bearing feature consists of a stabilizing track on the underside of the drawtube that provides extra rigidity for carrying heavy payloads (**Figure 2**). Drawtube flexure is virtually eliminated by stabilizing the drawtube within the focuser housing. The oversized 3"-diameter drawtube terminates in a 2" compression ring accessory collar, and a 1.25" compression ring accessory collar is also included.

The focuser's 10:1 fine focus adjustment helps you zero in on the exact focus point. Every 10 turns of the small, black fine focus knob equals a single turn of the large coarse focus knob, to enable the micro-adjustment necessary for the sharpest images possible. Use the coarse focus knob until your object is as close to focus as possible, then make fine adjustments with the black fine focus knob.

The focuser is also equipped with both a tension adjustment knob for the drawtube and a drawtube locking knob.

The tension adjustment knob is on the underside of the focuser while the locking knob is on top. We recommend keeping the tension adjustment knob fairly tight at all times as this will minimize drawtube flexure and slippage.

The focuser can be rotated to a desired angle prior to final focusing for astrophotographic framing by slightly loosening the focuser attachment collar (turning it counterclockwise), then rotating the focuser to the desired position before retightening the collar.

Extension Rings

Included with your Orion TTRC telescope are three thread-on extension rings (**Figure 3**). These extension rings are provided to allow multiple visual or photographic accessories to reach focus, depending on their backfocus requirements. They are



Figure 1. The 3" dual-speed linear bearing Crayford focuser features both 2" and 1.25" compression ring accessory collars.

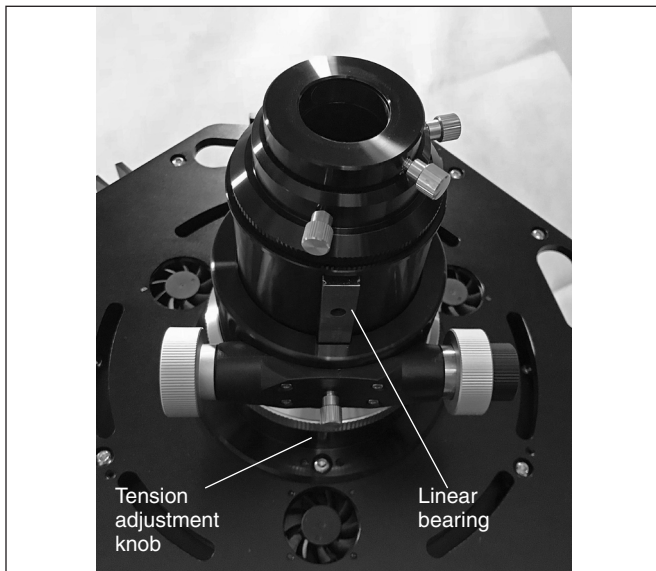

Figure 2. The focuser's stainless steel linear bearing rail adds extra rigidity to support heavy camera loads.



Figure 3. The TTRC includes one 2" and two 1" thread-on extension rings as well as a battery holder (eight AA batteries not included).

designed for installation individually or in combination between the optical tube and the focuser to take up unneeded back-focus. Refer to the Specifications at the end of this manual for the native backfocus distance of the Truss Tube Ritchey-Chretien telescopes.

If the focuser drawtube is fully extended and you are still unable to achieve focus you will need to install one or more

Depending on what equipment you use to observe or image with, you may need to add one or more of the included extension rings. To do so you must first remove the focuser from the optical tube by rotating the focuser attachment collar counterclockwise. Then thread the desired extension ring(s) onto the male threads on the telescope tube (**Figure 4**). Finally, re-attach the focuser by aligning the silver attachment collar over the exposed extension ring threads and turn it clockwise until tight. It may be useful to experiment with different combinations during the day before heading out into the field. Choose a target over 1/2 mile away to ensure you are simulating infinity focus. The goal is to reach focus with as little extension of the focuser drawtube as possible, to avoid drawtube flexure.

Depending on what equipment you use to observe or image with, you may need to add one or more of the included exten-



Figure 4. Remove the focuser to thread one or more extension rings onto the focuser tilt adjustment plate, then attach the focuser to the extension ring.

sion rings. The backfocus distance of your camera's sensor as well as the other components in your imaging train, e.g., focal reducer or flattener, filter wheel, or off-axis guider, will influence how much extension you will need to add between the optical tube and the focuser in order to reach focus.

Upper and Lower Mounting Bars

Orion Truss Tube Ritchey-Chretien astrographs have a D-style (Losmandy) dovetail mounting bar on both the top and bottom sides of the optical tube assembly (**Figure 5**). The bottom bar is for mounting the telescope on a compatible telescope mount equipped with a saddle that can accommodate a D-plate. The top bar allows piggyback mounting of a second telescope, a guidescope (or, as noted below, a finder scope with an optional dovetail finder scope base) or other accessories. Attachment to the dovetail bar will require adapter(s) compatible with a D-style plate. The length of the dovetail bars on the 10" TTRC are 9.8", on the 12" TTRC they are 14", on the 14" TTRC they are 15.5", and on the 16" TTRC they measure 16.2".

Attaching Optional Finder Scopes and Guiding Solutions

Orion TTRC telescopes are equipped with a dovetail finder scope base (**Figure 5**), which allows attachment of any Orion finder scope or reflex sight. It should also be noted that the top D-type mounting bar on the telescope has two sets of predrilled and tapped holes that allow attachment of an Orion



Figure 5. D-style dovetail bars are installed on both the top and bottom of the telescope (top bar shown). Two sets of threaded holes on the bar accommodate an optional Orion dovetail finder scope base.

dovetail finder scope base (part #7214) to the bar, should you desire to mount one there. The screws that are included with the #7214 dovetail base fit the pre-tapped holes in the bar.

Cooling the Telescope

Before observing or photographing with your Orion TTRC telescope, you should let it equilibrate to the outdoor temperature for a half hour or so. This will reduce thermal air currents that could soften or blur your images. Orion TTRC telescopes are each equipped with three small, low-vibration DC cooling fans on the rear cell to help accelerate the primary mirror cool-down time (**Figure 6**). The fans pull air in through the rear cell and blow it onto the back of the primary mirror, to facilitate thermal equilibration. The fans require a 12V power supply; a battery holder is included that accepts eight AA batteries (not included). A cable from the battery holder plugs into the DC input port on the rear cell. The fans start up as soon as the battery pack is plugged in; there is no ON/OFF switch. Alternatively, the fans can be powered by a rechargeable 12V DC field battery that has a 5mm/2.1mm plug.

Although the fans are a low-vibration model, we recommend turning them off while actively imaging to avoid any effect on image stability from vibration or blowing air.

Collimation

The optics in your new TTRC have been aligned at the factory. However, rough handling during transit may warrant periodic re-adjustments. The secondary mirror is precisely center marked with a small adhesive ring (**Figure 7**) to aid in collimation. This ring does not affect the view through the telescope,

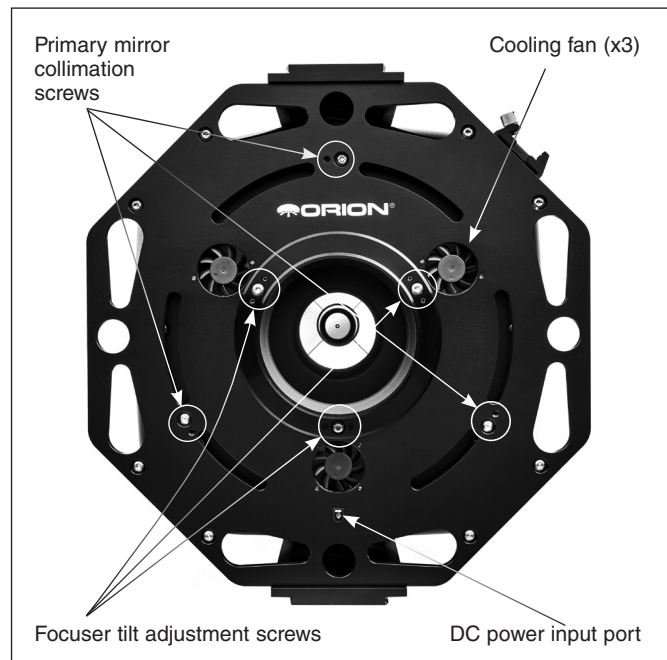

Figure 6. The rear cell of the TTRC has three built-in 12V DC-powered fans and collimation adjustment screws for both the primary mirror and focuser.

so it should not be removed. You will need a laser collimator or a Cheshire eyepiece to check and adjust collimation. We recommend doing the collimation during the daytime; it can be done indoors.

Remove any extension rings and attach the focuser directly to the optical tube. Set up your telescope in a well-lit room with the telescope oriented horizontally, and point it at a light colored wall.

Focuser Tilt Adjustment

The first step will be to check that the focuser is precisely aligned with the secondary mirror. On the TTRCs, the focuser is independently collimatable. This step is best done with a laser pointer.

Insert the laser pointer into the 1.25" or 2" focuser collar (depending on the diameter of your laser collimator's barrel) and turn it on. Assuming the laser collimator beam is exactly parallel with the collimator's mechanical axis, the laser beam should hit the secondary mirror exactly in the middle of the center ring on the secondary mirror. If it does, you can skip to the next section, "Secondary Mirror Adjustment."

If the laser dot does not land in the middle of the center ring on the secondary mirror, you need to adjust the tilt of the focuser as follows.

You will use the three sets of three screws on the focuser tilt adjustment plate, shown in **Figure 6**. Each set consists of a center silver-colored socket head screw flanked by two smaller black socket head screws. The small black screws are merely locking screws, which you should loosen a couple of turns before adjusting the mirror's tilt. The larger silver screws are spring-loaded collimation screws that tilt the focuser. You will

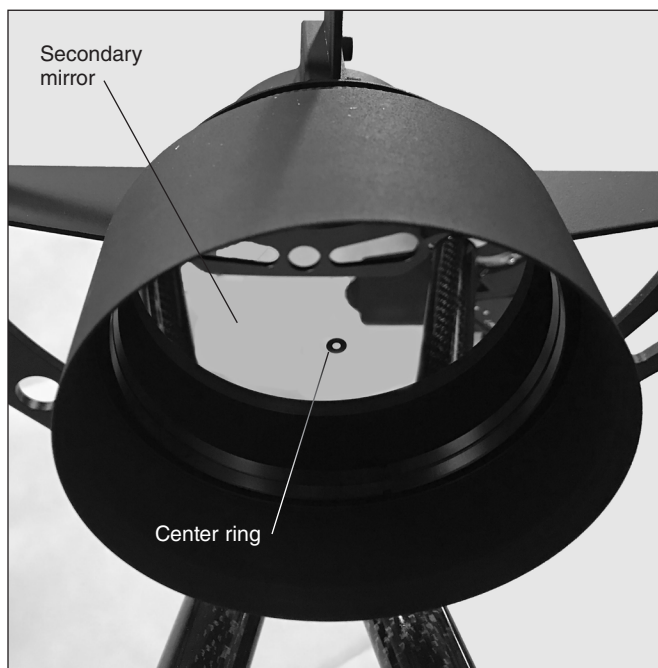

Figure 7. A small adhesive ring marks the exact center of the secondary mirror, to aid in precise collimation.

need a 2mm and 4mm Allen wrench to adjust the small and large screws, respectively.

Turn the collimation screws only a fraction of a turn at a time. Turn one clockwise or counterclockwise and then check whether the laser dot is centered in the secondary mirror ring, or is closer to center, or farther from center. Using trial and error, keep tweaking the collimation screws accordingly, each time checking the laser dot's position in the center ring.

When the laser dot is finally exactly centered in the ring, lightly tighten all six locking screws to fix the focuser in that tilt position.

Secondary Mirror Adjustment

The next step will be to adjust the tilt of the secondary mirror. This can also be done with a laser collimator, however we will describe doing it with a simple Cheshire collimating eyepiece.

NOTE: Only adjust the three screws around the perimeter of the secondary mirror holder -- do not adjust the center screw! (Figure 8). Adjusting the center screw can change the distance between the primary and secondary mirrors, which you do not want to do, or could even cause the secondary mirror to fall off, which will not be covered under warranty.

Insert the Cheshire eyepiece into the focuser via the included 1.25" adapter and tighten the thumbscrew on the adapter. Make sure that a bright source of light, like a ceiling light or flashlight, is aimed at the 45° reflecting surface of the Cheshire.

Look through the Cheshire eyepiece. You should see a small black dot and a dark ring within a larger bright circle. The dot is the hole of your Cheshire eyepiece. The dark ring is the center mark on the secondary mirror. And the bright circle is the reflective 45-degree surface of the Cheshire. The larger black circle outside that is the secondary mirror holder (**Figure 9A**).

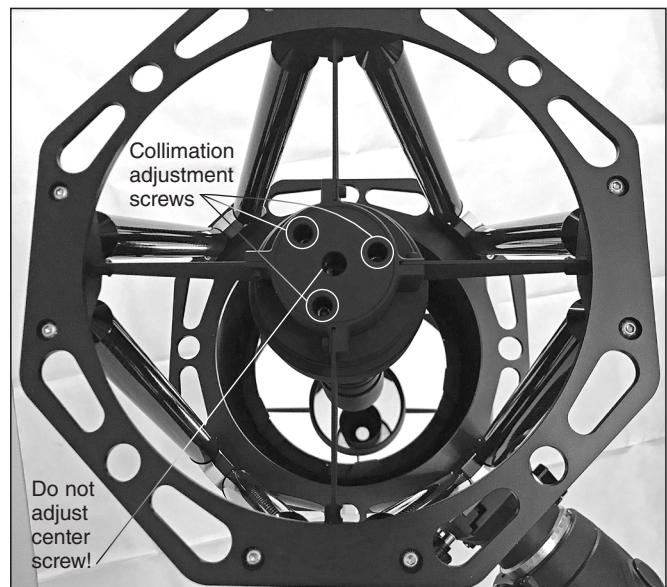

Figure 8. Secondary mirror collimation is done by adjusting the three socket head capscrews on the front of the telescope.

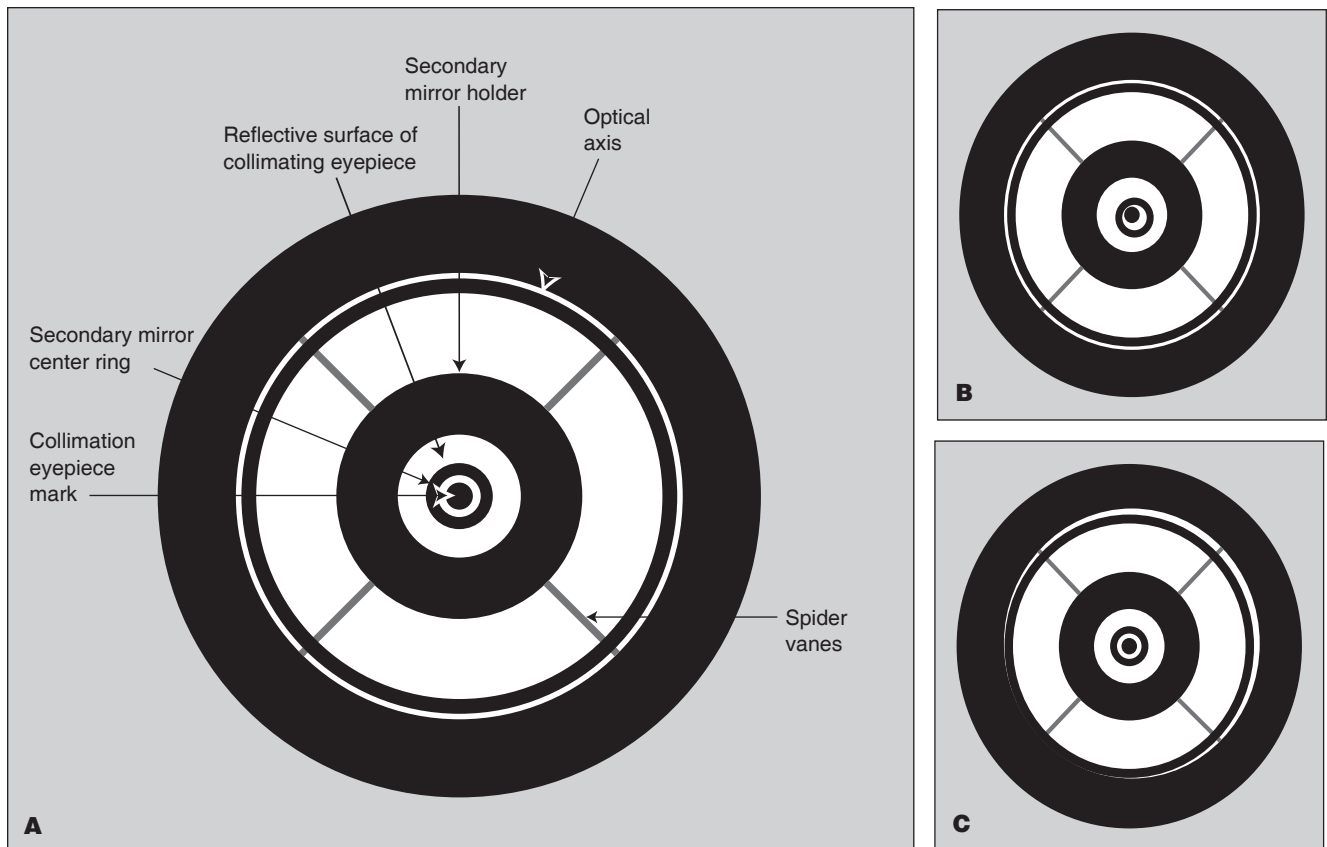

Figure 9. The view through a collimating eyepiece (not to scale). **A)** Shows the Ritchey-Chretien aligned with all components identified. **B)** Shows the secondary out of alignment. **C)** Shows the optical axis out of alignment.

If your scope is in good collimation, the black dot will be dead center in the dark ring, which will in turn be centered in the bright circle. If that's the case, no further adjustments to the secondary mirror will be necessary. The optical axis is denoted by a thin white circle on the outer edge. You can disregard that for the time being; it will be covered in the following section.

If the view looks something like **Figure 9B** — with the dot of the collimation eyepiece NOT centered in the secondary center ring — you will need to adjust the three collimation set-screws at the front of the secondary mirror holder (**Figure 8**). This will adjust the tilt of the secondary, changing the relative position of the secondary center ring when peering through the collimation eyepiece.

A 4mm hex key is required to perform collimation on the secondary mirror. When adjusting one of these screws you will need to make counter-adjustments to the other two. Therefore, if you are loosening one screw you will need to tighten the other two. At the end of the process you want all three collimation screws to be reasonably tight so the secondary mirror won't shift while the scope is in use.

Always start by *loosening* one screw. Adjust the screws only very slightly — by no more than 1/10 turn at a time, and one screw at a time before checking the view through the Cheshire again to see how things changed. Only tiny adjustments

should be required to achieve collimation. This will also aid in the prevention of accidentally putting the telescope grossly out of collimation. With each tiny tweak of a screw, make a mental note of which way and how far the center dot moved, as that will inform which screw to turn next and by how much. Experiment with different combinations of loosening/tightening the three screws one by one until the collimation eyepiece's black dot is centered in the dark ring of the secondary mirror. The correct alignment of the secondary mirror is critical in determining if the optical axis requires alignment. Be sure you have properly aligned the secondary mirror before proceeding to the next step.

Optical Axis (Primary Mirror) Adjustment

The optical axis is denoted by a thin outline of light (white) around the perimeter of the view through the collimating eyepiece (**Figure 9A**). If this outline is not a perfect circle of uniform thickness, as in **9C**, that's an indication that the optical axis (primary mirror) needs adjustment. This adjustment will require a 4mm and 2mm hex key.

Note that there are three pairs of screws on the rear cell of the optical tube, located about halfway between the focuser tilt adjustment plate and the outer edge of the rear cell (**Figure 6**). Each pair consists of a silver-colored Allen screw flanked by a smaller black Allen screw. The small black screws are

merely locking screws, which you should loosen a bit before adjusting the mirror's tilt. The larger chrome screws are spring-loaded collimation screws that actually adjust the tilt of the primary mirror. Turn these collimation screws clockwise or counterclockwise only a fraction of a turn at a time. Turn one and check the view through the Cheshire to see if it improved the white optical axis ring. Keep tweaking the collimation screws, each time checking the optical axis ring, until it is concentric and uniform in width. Then lightly tighten the three locking set-screws to fix the mirror in that position.

After adjusting the optical axis, re-check the collimation of the secondary mirror and make any necessary adjustments, then recheck the optical axis collimation. Optical axis collimation will not need to be performed very often, if ever.

Star Testing

A star test can be performed to confirm the collimation accuracy of the telescope. The adjustment procedure on the telescope is the same as described above; testing, however, will be done in the night sky using a real star and you will not use the Cheshire eyepiece.

Choose a star close to the zenith (straight overhead) rather than at the horizon to minimize atmospheric distortions. Using Polaris as your target star can be helpful as minimal drift adjustments will be required.

Do not use a star diagonal while performing this procedure. Rather, place an eyepiece directly into the 1.25" adapter in the focuser. It should be an eyepiece that provides moderate to high magnification. You may need to add all three of the extension rings in front of the focuser to be able to reach focus. Center the star in the field of view. Slowly de-focus the image with the focusing knob until you can see a series of concentric diffraction rings form around the dark disk in the center. That dark disk is the shadow of the secondary mirror. In a well collimated telescope, the diffraction rings should appear round and concentric, with the dark disk exactly in the center (**Figure 10**). If the dark central disk is off center, the scope is out of collimation. Adjust the collimation of the secondary mirror and, only if necessary, the primary mirror while monitoring the defocused star until the dark central disk is exactly centered in the diffraction rings.

NOTE: *It is important when checking or adjusting the collimation using a star, that the star be positioned in the center of the eyepiece's field of view. If it isn't, the optics will always appear out of collimation, even though they may be perfectly aligned! It is critical to keep the star centered, so over time you may need to make slight corrections to the telescope's position.*

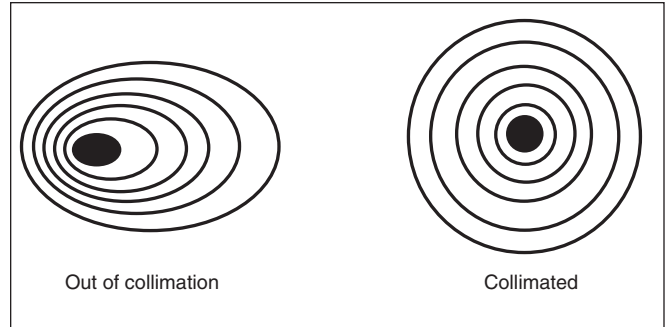

Figure 10. A de-focused view of a bright star through an eyepiece. Proper collimation will show concentric, symmetrical diffraction rings with a dark spot exactly in the center, as in the image on the right. If the spot is off-center, the scope needs collimation.

Care and Cleaning of the Optics

Do not disassemble the TTRC telescope for any reason, including to clean the mirror. A small amount of dust and particulates on the mirror's surface will not affect performance. In the event internal cleaning is necessary the telescope should be shipped to Orion Telescopes and Binoculars for service. This telescope does not contain user-serviceable parts and disassembly of the components will void the warranty. When not in use, please use the supplied plastic dust covers to keep dust and particulates off of the primary and secondary mirrors.

Specifications

10" f/8 Truss Tube Ritchey-Chrétien

Optical configuration	Ritchey-Chrétien
Optical tube	Carbon fiber Serrurier truss tube design with CNC stainless steel and aluminum components
Aperture	250mm (10")
Focal length	2000mm
Focal ratio	f/8
Primary mirror figure	Hyperbolic
Primary mirror material	Quartz
Primary mirror coating	Enhanced aluminum, 96% reflectivity, with SiO ₂ overcoat
Secondary mirror figure	Hyperbolic
Secondary mirror material	Quartz
Secondary mirror coating	Enhanced aluminum, 96% reflectivity, with SiO ₂ overcoat
Secondary mirror diameter	105mm
Central obstruction diameter	110mm
Focuser	3" dual-speed (10:1) linear bearing Crayford, with 2" and 1.25" collars
Focuser load capacity	11 lbs. (5 kg)
Drawtube travel:	50mm
Backfocus distance	239.8mm from rear support plate
Cooling fans	Three fans, built into rear cell; 12V DC powered
Telescope length	29.5"
Telescope diameter	15.5"
Weight	35 lbs.

12" f/8 Truss Tube Ritchey-Chrétien

Optical configuration	Ritchey-Chrétien
Optical tube	Carbon fiber Serrurier truss tube design with CNC stainless steel and aluminum components
Aperture	304mm (12")
Focal length	2432mm
Focal ratio	f/8
Primary mirror figure	Hyperbolic
Primary mirror material	Quartz
Primary mirror coating	Enhanced aluminum, 96% reflectivity, with SiO ₂ overcoat
Secondary mirror figure	Hyperbolic
Secondary mirror material	Quartz
Secondary mirror coating	Enhanced aluminum, 96% reflectivity, with SiO ₂ overcoat
Secondary mirror diameter	140mm
Central obstruction diameter	150mm
Focuser	3" dual-speed (10:1) linear bearing Crayford, with 2" and 1.25" collars
Focuser load capacity	11 lbs. (5 kg)
Drawtube travel:	50mm
Backfocus distance	284.1mm from rear support plate
Cooling fans	Three fans, built into rear cell; 12V DC powered
Telescope length	38.5"
Telescope diameter	17.25"
Weight	52 lbs.

14" f/8 Truss Tube Ritchey-Chrétien

Optical configuration:	Ritchey-Chrétien
Optical tube	Carbon fiber truss tube design with CNC stainless steel and aluminum components
Aperture	356mm (14.0")
Focal length	2848mm
Focal ratio	f/8
Primary mirror figure:	Hyperbolic
Primary mirror material	Quartz
Primary mirror coating	Enhanced aluminum, 96% reflectivity, with SiO ₂ overcoat
Secondary mirror figure	Hyperbolic
Secondary mirror material	Quartz
Secondary mirror coating	Enhanced aluminum, 96% reflectivity, with SiO ₂ overcoat
Secondary mirror diameter	150mm
Central obstruction diameter	166mm
Focuser	3" dual-speed (10:1) linear bearing Crayford, with 2" and 1.25" collars
Focuser load capacity	11 lbs. (5 kg)
Drawtube travel:	50mm
Backfocus distance	290.2mm from rear support plate
Cooling fans	Three fans, built into rear cell; 12V DC powered
Telescope length	44.9"
Telescope diameter	21.0"
Weight	66.1 lbs.

16" f/8 Truss Tube Ritchey-Chrétien

Optical configuration:	Ritchey-Chrétien
Optical tube	Carbon fiber truss tube design with CNC stainless steel and aluminum components
Aperture	406mm (16.0")
Focal length	3248mm
Focal ratio	f/8
Primary mirror figure:	Hyperbolic
Primary mirror material	Quartz
Primary mirror coating	Enhanced aluminum, 96% reflectivity, with SiO ₂ overcoat
Secondary mirror figure	Hyperbolic
Secondary mirror material	Quartz
Secondary mirror coating	Enhanced aluminum, 96% reflectivity, with SiO ₂ overcoat
Secondary mirror diameter	170mm
Central obstruction diameter	189mm
Focuser	3" dual-speed (10:1) linear bearing Crayford, with 2" and 1.25" collars
Focuser load capacity	11 lbs. (5 kg)
Drawtube travel:	50mm
Backfocus distance	310.9mm from rear support plate
Cooling fans	Three fans, built into rear cell; 12V DC powered
Telescope length	49.6"
Telescope diameter	22.2"
Weight	92.6 lbs.

One-Year Limited Warranty

This Orion product is warranted against defects in materials or workmanship for a period of one year from the date of purchase. This warranty is for the benefit of the original retail purchaser only. During this warranty period Orion Telescopes & Binoculars will repair or replace, at Orion's option, any warranted instrument that proves to be defective, provided it is returned postage paid. Proof of purchase (such as a copy of the original receipt) is required. This warranty is only valid in the country of purchase.

This warranty does not apply if, in Orion's judgment, the instrument has been abused, mishandled, or modified, nor does it apply to normal wear and tear. This warranty gives you specific legal rights. It is not intended to remove or restrict your other legal rights under applicable local consumer law; your state or national statutory consumer rights governing the sale of consumer goods remain fully applicable.

For further warranty information, please visit www.OrionTelescopes.com/warranty.



Corporate Offices: 89 Hangar Way, Watsonville CA 95076 - USA
Toll Free USA & Canada: (800) 447-1001
International: +1(831) 763-7000
Customer Support: support@telescope.com

Copyright © 2022 Orion Telescopes & Binoculars. All Rights Reserved. No part of this product instruction or any of its contents may be reproduced, copied, modified or adapted, without the prior written consent of Orion Telescopes & Binoculars.