

Orion® EQ-13 Equatorial Telescope Mount and Tripod

#55026



 **ORION**®
TELESCOPES & BINOCULARS
AN EMPLOYEE-OWNED COMPANY

Corporate Offices: 89 Hangar Way, Watsonville CA 95076 - USA

Toll Free USA & Canada: (800) 447-1001

International: +1(831) 763-7000

Customer Support: support@telescope.com

Copyright © 2022 Orion® Telescopes & Binoculars. All Rights Reserved. No part of this product instruction or any of its contents may be reproduced, copied, modified or adapted, without the prior written consent of Orion Telescopes & Binoculars.

Congratulations on your purchase of an Orion telescope mount. Your new EQM-13 Equatorial Mount and Tripod is quality equatorial mount designed for astronomical viewing with small telescopes. These instructions will help you assemble and properly use your new mount. Please read them over thoroughly before getting started.

I. Parts

Part	Qty
A — Tripod	1
B — Equatorial mount	1
C — Accessory tray	1
D — Latitude adjustment T-bolt	2
E — Slow-motion cables	1
F — Counterweight shaft	1
G — Counterweight	1

WARNING: Do NOT look at the Sun without a professionally made solar filter on the telescope; serious eye damage may result if you look at the Sun with any unfiltered optical instrument. Do not leave the telescope unsupervised around children. Always cover the lenses when leaving the telescope in direct sunlight.

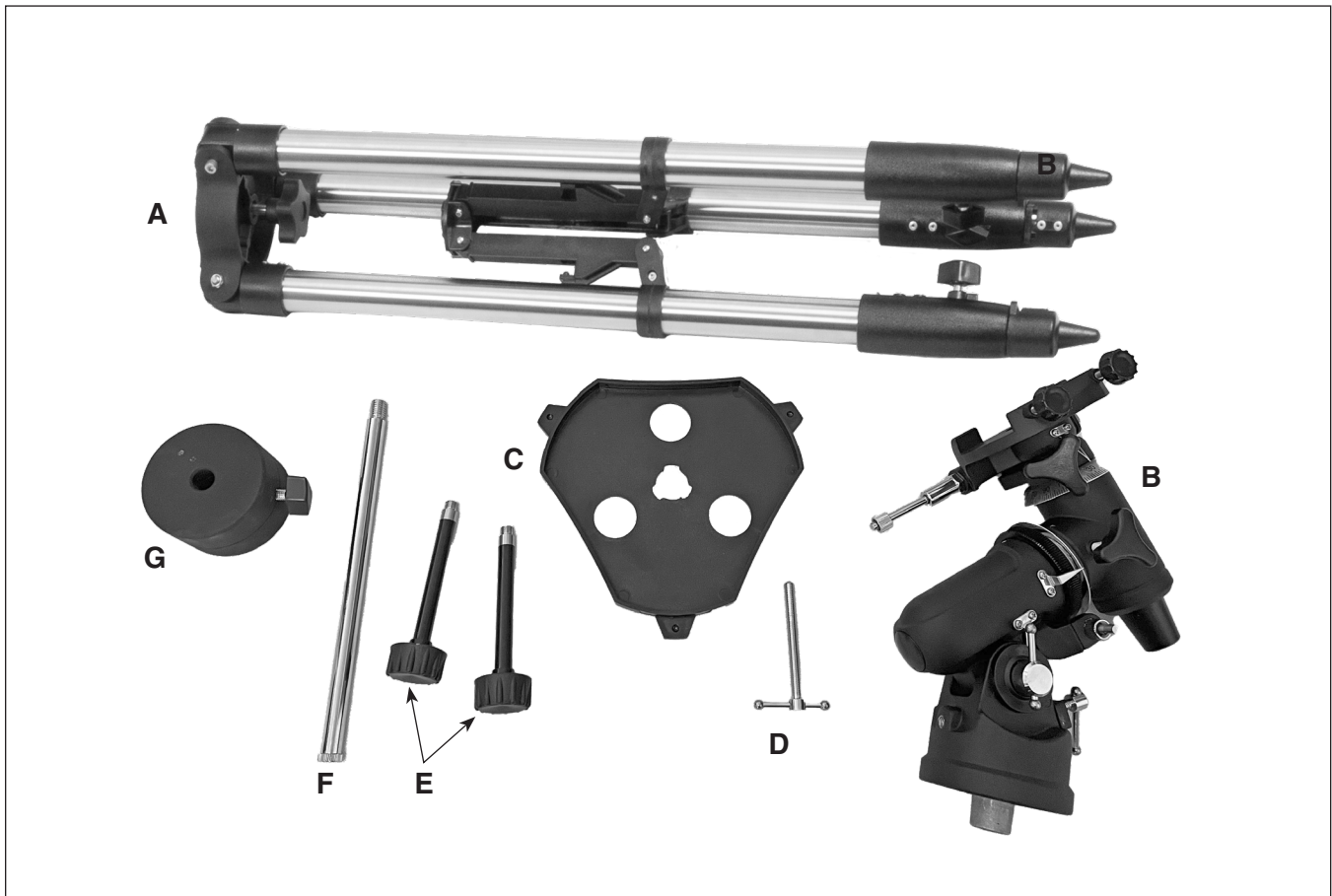

Figure 1. Included components of the Orion EQ-13 Equatorial Mount.

II. Assembly

1. Spread the tripod (A) legs apart and stand the tripod on the ground. You can extend the legs to the desired height later using the leg lock knobs. For now just keep them fully retracted.
2. Attach the accessory tray (C) by registering its center cut-out over the center of the tripod leg brace assembly (**Figure 2A**). Press the tray down and twist it until the tray tabs click in place under the three retaining clips on the brace (**2B**).
3. Now you will attach the equatorial mount (B) to the tripod. Place the base of the mount onto the tripod's mounting platform, and then simply thread the captive mount attachment knob under the tripod clockwise up into the mount until it is tight (**Figure 3**).
4. Next, thread the second latitude adjustment T-bolt (D) into the hole in the mount base. (One T-bolt comes pre-installed; the other one you must install yourself.) **Figure 3** shows the two installed latitude adjustment T-bolts.
5. Install the counterweight shaft (F) by threading it into the counterweight shaft collar (**Figure 4A**).
6. Now remove the safety stop at the end of the shaft and slide counterweight (G) onto the shaft (**Figure 4B**). You may have to loosen the counterweight lock knob to allow the weight to slide onto the shaft. Once the counterweight is on the shaft, replace the safety stop.
7. Attach the two slow-motion cables (E) to the RA and Dec gear shafts by threading the collar on the gear shaft onto the cable until tight (**Figure 5**).

The EQ mount is now fully assembled. To install an optical tube on the mount, make sure the tube is equipped with a compatible Vixen-style dovetail bar.

III. Installing a Telescope Optical Tube On the Mount

Before installing an optical tube, ensure that the right ascension and declination lock knobs (**Figure 6**) are tightened so that the mount won't swivel accidentally when you're attaching the tube rings or the optical tube. And of course make sure the counterweight is installed on the counterweight shaft.

Make sure the two saddle clamp knobs are backed out sufficiently to allow the dovetail bar to seat properly. Then lift the optical tube and set the dovetail mounting bar into the mount's saddle. When the dovetail bar is seated in the saddle, tighten the saddle clamp knobs until tight.

IV. Balancing the Telescope

To insure smooth movement of the telescope on both axes of the equatorial mount, it is imperative that the optical tube be properly balanced. First we'll balance the telescope with respect to the R.A. axis, then the Dec. axis.

1. Keeping one hand on the telescope optical tube (sold separately), loosen the R.A. lock knob (see **Figure 7A**).

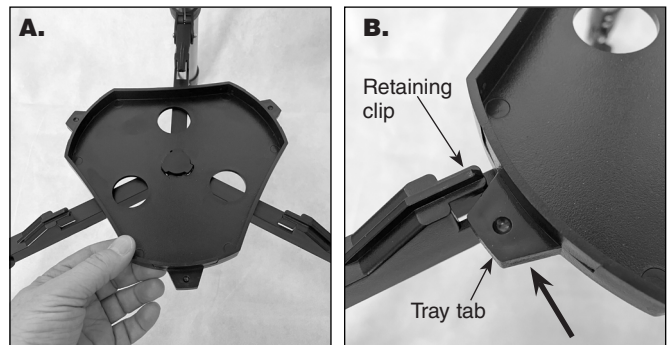

Figure 2. **A**) Place center of accessory tray over the center of the leg brace assembly. **B**) Press down and twist tray until the tabs click under retaining clips.

Make sure the Dec. lock knob is locked, for now. The telescope should now be able to rotate freely about the R.A. axis. Rotate it until the counterweight shaft is parallel to the ground (i.e., horizontal), as in **Figure 7A**.

2. Now loosen the counterweight lock knob and slide the weight along the shaft until it exactly counterbalances the telescope. That's the point at which the shaft remains horizontal even when you let go of the telescope with both hands.
3. Retighten the counterweight lock knob. The telescope is now balanced on the R.A. axis.
4. To balance the telescope on the Dec. axis, first tighten the R.A. lock knob, with the counterweight shaft still in the horizontal position.
5. With one hand on the telescope optical tube, loosen the Dec. lock knob (see **Figure 7B**). The telescope should now

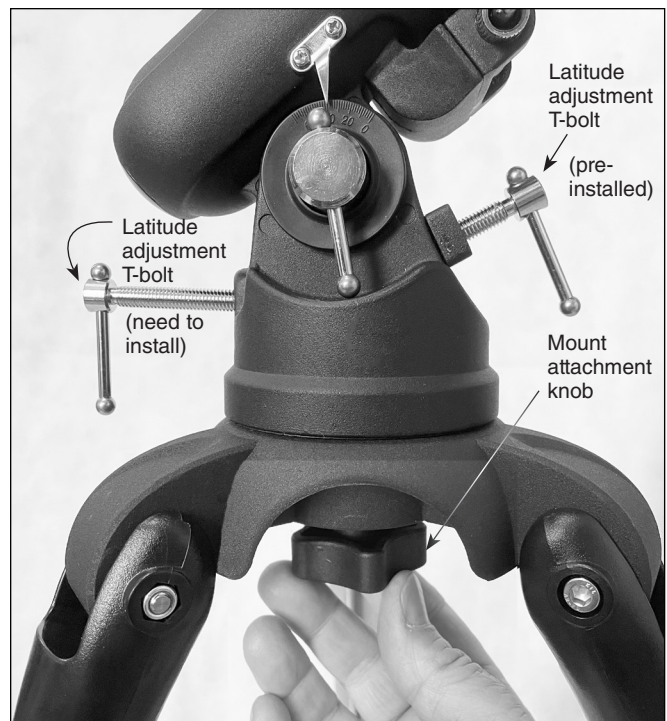

Figure 3. Secure the EQ mount to the tripod with the mount attachment knob.

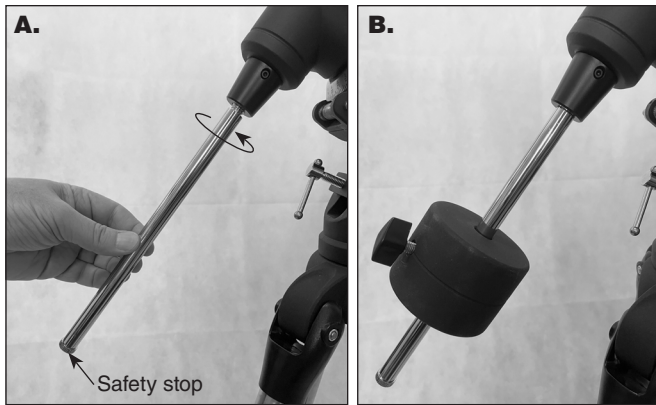

Figure 4. **A)** Thread the counterweight shaft onto the mount. **B)** After removing the safety stop, slide the counterweight onto the shaft.

be able to rotate freely about the Dec. axis. If the front of the telescope swings downward, that means you need to move it back in the mount's saddle. If the front of the telescope swings upward, then you need to shift the telescope forward in the saddle. To move the telescope in the saddle, loosen the saddle lock knobs just a little – so the dovetail bar doesn't accidentally pop out of the saddle. Position the telescope so it remains horizontal when you carefully let go with both hands. This is the balance point.

6. Retighten the saddle clamp knobs.

The telescope is now balanced on both axes. Now when you loosen the lock knob on one or both axes and manually point the telescope, it should move without resistance and should not drift from where you point it.



Figure 5. Attach the two slow-motion cables to the mount.

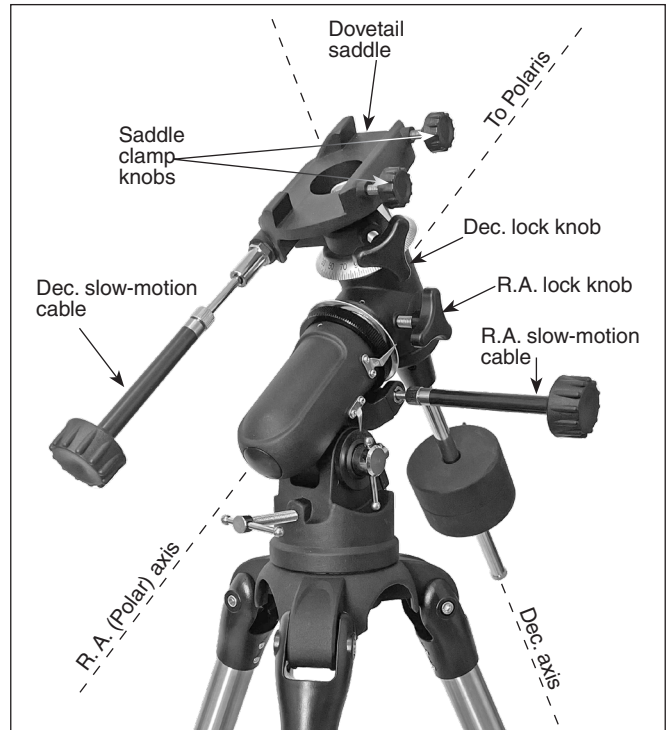

Figure 6. The assembled EQ-13 mount looks like this.

V. Polar Alignment

When you look at the night sky, you no doubt have noticed that the stars appear to move slowly from east to west over time. That apparent motion is caused by the Earth's rotation (from west to east). An equatorial mount is designed to compensate for that motion, allowing you to easily "track" the movement of astronomical objects, thereby keeping them from drifting out of your telescope's field of view while you're observing.

This is accomplished by slowly rotating the telescope on its right ascension (R.A.) axis, using only the R.A. slow-motion knob. But first the R.A. axis of the mount must be aligned with the Earth's rotational (polar) axis—a process called polar alignment.

For Northern Hemisphere observers, approximate polar alignment is achieved by pointing the mount's right ascension axis at the North Star, Star (Polaris). It lies within 1° of the north celestial pole (NCP), which is an extension of the Earth's rotational axis out into space. Stars in the Northern Hemisphere appear to revolve around the NCP.

To find Polaris in the sky, look north and locate the pattern of the Big Dipper (**Figure 8**). The two stars at the end of the "bowl" of the Big Dipper point approximately to Polaris.

Observers in the Southern Hemisphere aren't so fortunate to have a bright star so near the south celestial pole (SCP). The star Sigma Octantis lies about 1° from the SCP, but it is barely visible with the naked eye (magnitude 5.5).

To polar align the equatorial mount:

1. Roughly level the mount by adjusting the length of the three tripod legs as needed (**Figure 9**).

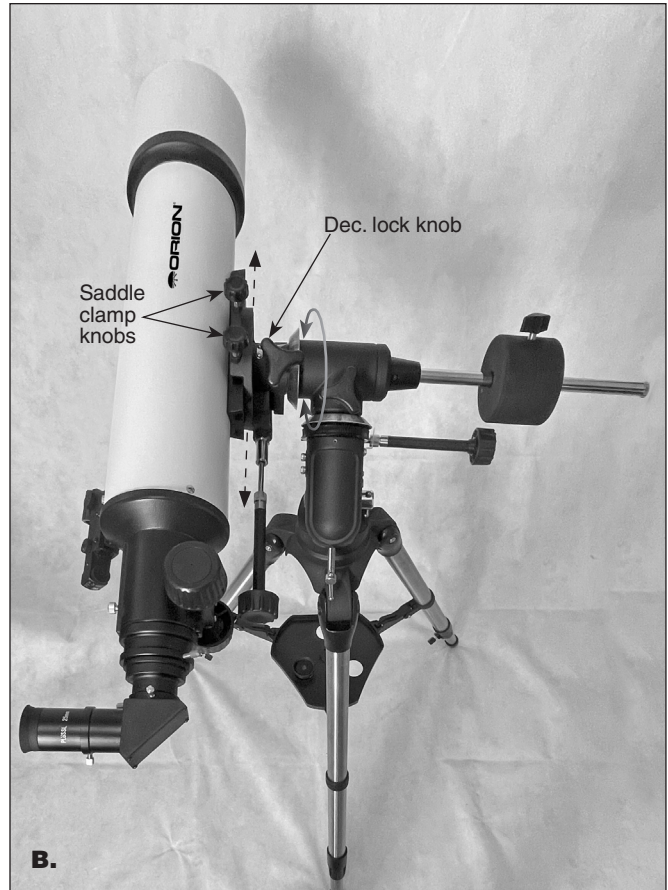
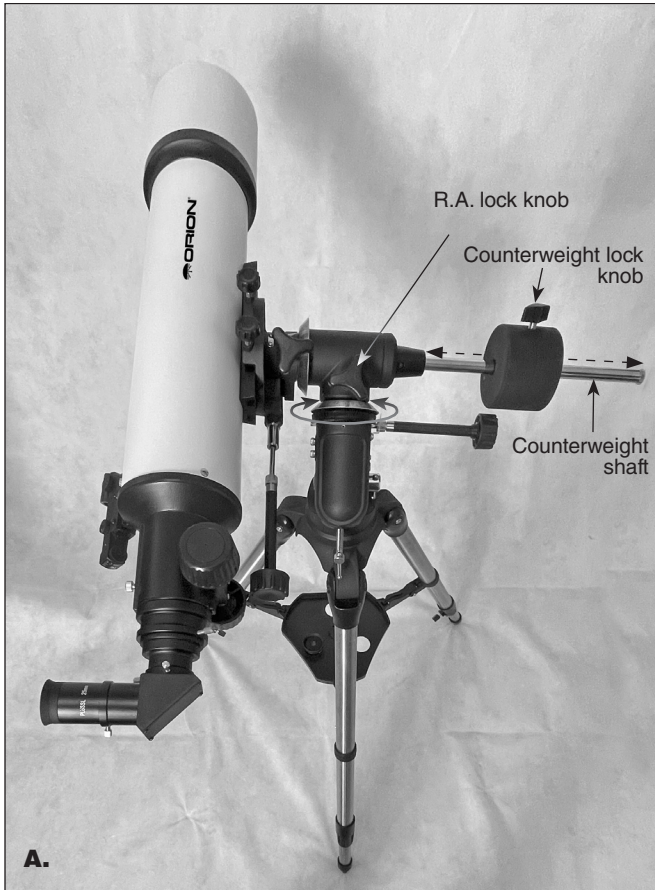

Figure 7. A) Balance a telescope in right ascension by sliding the counterweight along the shaft until it counterbalances the telescope. **B)** Balance the telescope on the declination axis by sliding the dovetail mounting bar forward or back in the mount's saddle.

2. Loosen the latitude lock knob a half turn or so (**Figure 10**).
3. Using the two latitude adjustment T-bolts, set the latitude so that the pointer on the latitude scale indicates the latitude of your observing location. (Loosen one latitude adjustment T-bolt before tightening the other.) If you don't know your location's latitude, you can look it up on the internet. For example, if your latitude is 35° North, set the pointer to 35. Then retighten the latitude lock knob. The latitude setting should not have to be adjusted again unless you move to a different viewing location some distance away.
4. Next, loosen the mount attachment knob (see **Figure 10**) just enough to allow you to rotate the mount in azimuth. Then rotate the mount by hand so the R.A. axis points roughly at Polaris (**Figure 6**). If you cannot see Polaris directly from your observing site, consult a compass and rotate the mount so the telescope points North. Then retighten the mount attachment knob.

The equatorial mount is now (roughly) polar aligned. From this point on in your observing session, you should not make any further adjustments to the azimuth or the latitude of the mount, nor should you move the tripod. Doing

so will ruin the polar alignment. The telescope should henceforth be moved only about its R.A. and Dec. axes.

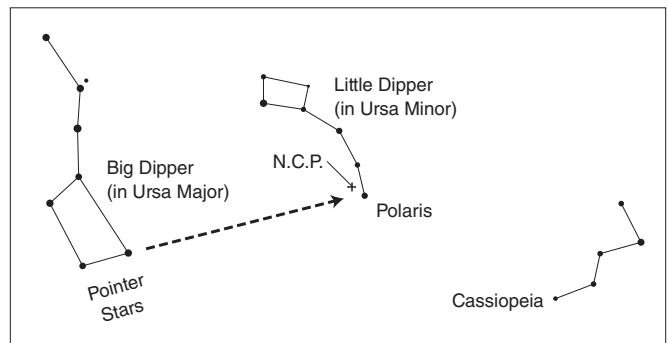

Figure 8. To find Polaris in the night sky, look north and find the Big Dipper. Extend an imaginary line from the two "Pointer Stars" in the bowl of the Big Dipper. Go about five times the distance between those stars and you'll reach Polaris, which lies within 1° of the north celestial pole (NCP).



Figure 9. Adjust the tripod leg length by loosening the leg lock knob, then extending the leg to the desired length. Then retighten the knob.



Figure 11. The R.A. and Dec. setting circles allow you to locate an object by its R.A. and Dec. coordinates.

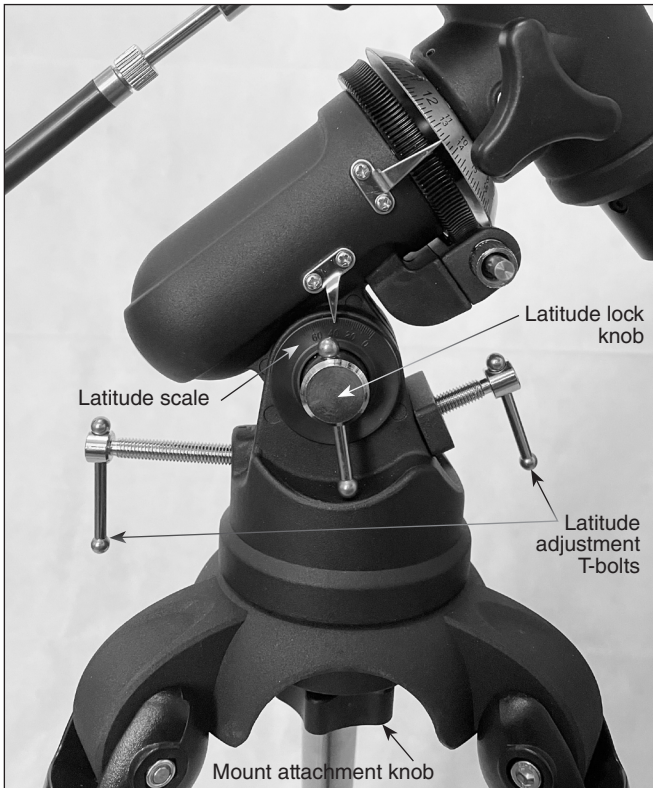

Figure 10. Loosen the latitude lock knob, then use the two latitude adjustment T-bolts to set the latitude scale pointer to your location's latitude.

VI. Using the EQ-13 Mount

Using the R.A. and Dec. Slow-Motion Control Cables

The R.A. and Dec. slow-motion control cables (see **Figure 6**) allow fine adjustment of the mount's position to center objects within the telescope's field of view. Before using the cables, manually "slew" the mount to point the telescope in the vicinity of the desired target. Do this by loosening the R.A. and Dec. lock knobs and moving the telescope about the mount's R.A. and Dec. axes. Once the telescope is pointed somewhere close to the object to be viewed, retighten the mount's R.A. and Dec. lock knobs.

The object should now be visible somewhere in the field of view of the telescope's finder scope or reflex sight. If it isn't, use the slow-motion controls to scan the surrounding area of sky. **Note: when using the slow motion cables, the R.A. and Dec lock knobs should be tightened, not loose.** When the object is visible in the finder scope, use the slow-motion controls to center it. Now, look in the telescope's eyepiece and use the slow-motion controls to center it in the eyepiece.

The R.A. slow motion cable can turn the mount's R.A. axis a full 360 degrees. However, the Dec. slow-motion cable has a limited range of about 25 degrees. If you reach the end of the range of motion – and you cannot turn the knob further – you should reverse direction by 10 degrees or so, then release the Dec. lock knob and move the telescope by hand back

to about where it was pointed before the slow-motion cable stopped turning. Now you should be able to use the slow motion cable again for fine pointing in either direction.

Tracking Celestial Objects

When you observe a celestial object through the telescope, you'll see it drift slowly across the field of view. To keep it in the field, assuming the equatorial mount is polar aligned, just turn the R.A. slow-motion control cable counterclockwise to track. The Dec. slow-motion control cable is not needed for tracking. Objects will appear to move faster at higher magnifications, because the field of view is narrower.

Optional Electronic Drive for Automatic Tracking

An optional DC electronic drive is available for the EQM-13 equatorial mount. This battery-operated drive provides automated, hands-free tracking. Objects will then remain stationary in the field of view without any manual adjustment of the R.A. slow-motion control cable.

Understanding the Setting Circles

The two setting circles on an equatorial mount enable you to locate celestial objects by their "celestial coordinates." Every object resides in a specific location on the "celestial sphere." That location is denoted by two numbers: its right ascension (R.A.) and declination (Dec.). In the same way, every location on Earth can be described by its longitude and latitude. R.A. is similar to longitude on Earth, and Dec. is similar to latitude. The R.A. and Dec. values for celestial objects can be found in any star atlas or online planetarium app.

On the EQ-13 mount, the R.A. setting circle is scaled in hours, from 1 through 24, with small marks in between representing 10-minute increments (**Figure 11**). The numbers at the base of the setting circle scale apply to the Northern Hemisphere while the numbers above them apply to viewing in the Southern Hemisphere.

The Dec. setting circle is denoted in degrees, with each main mark representing 10° increments (**Figure 11**). Values of Dec. coordinates range from +90° to -90°. The 0° mark indicates the celestial equator. For this mount, the number scale goes to 90 on either side of 0 – there are no (+) or (-) signs. When the telescope is pointed north of the equator, actual values of Dec. are negative.

For example, the coordinates for the Orion Nebula (M42) are:

R.A. 5 hr 35.4 min, Dec. -5° 27'

That's 5 hours and 35.4 minutes in right ascension, and -5 degrees and 27 arc-minutes in declination (there are 60 arc-minutes in 1 degree of declination).

Before you can use the setting circles to locate objects, the mount must be polar aligned, and the setting circles must be calibrated. The easiest way to calibrate the setting circles is to point the telescope at an identifiable bright star, center it in the eyepiece, then set the setting circles to the star's published coordinates, which you can find in a star atlas or astronomical software program, or perhaps on the internet.

Calibrating the Setting Circles

Using a star atlas or astronomy planetarium program, identify a bright star visible in your sky. Some smartphone astronomy apps allow you to hold your phone up to the sky and the app

will identify the stars and constellations visible in the direction you're pointing to. Note the right ascension and declination coordinates of the star.

Let's take as an example Altair, in the constellation Aquila. Its coordinates are:

R.A. 19 hr 51 min, Dec 8° 52'

1. Loosen the R.A. and Dec. lock knobs on the equatorial mount, so the telescope optical tube can move freely.
2. Point the telescope at Altair. Lock the R.A. and Dec. lock knobs. Center the star in the eyepiece with the slow-motion control cables.
3. Rotate the R.A. setting circle until the metal arrow indicates 19 hr 51 min.
4. Then rotate the Dec. setting circle until the metal arrow indicates +8° 52'

Note that the setting circles may be a little hard to rotate. But just grab it firmly around the edge and twist it and it will rotate.

Finding Objects with the Setting Circles

Now that both setting circles are calibrated, look up the coordinates of an object you wish to view.

1. Loosen the R.A. lock knob and rotate the telescope until the R.A. value from the star atlas matches the reading on the R.A. setting circle. Remember to use the lower set of numbers on the R.A. setting circle if you're in the Northern hemisphere. Retighten the lock knob.
2. Loosen the Dec. lock knob and rotate the telescope until the Dec. value from the star atlas matches the reading on the Dec. setting circle. Remember that values of the Dec. setting circle are positive when the telescope is pointing north of the celestial equator (Dec. = 0°), and negative when the telescope is pointing south of the celestial equator. Retighten the lock knob.

Most setting circles are not accurate enough to put an object dead-center in the telescope's eyepiece, but they should place the object somewhere within or near the field of view of the finder scope, assuming the equatorial mount is accurately polar aligned. Use the slow-motion controls to center the object in the finder scope, and it should appear in the telescope's field of view.

The R.A. setting circle must be re-calibrated every time you wish to locate a new object. Do so by calibrating the setting circle for the centered object before moving on to the next one.

Confused About Pointing the Telescope?

Beginners occasionally experience some confusion about how to point the telescope overhead or in other directions. One thing you DO NOT do is make any adjustment to the mount's latitude setting or to its azimuth position. That will throw off the mount's polar alignment. Once the mount is polar aligned, the telescope should be moved only about the R.A. and Dec. axes. This is done by loosening one or both of the R.A. and Dec. lock knobs and moving the telescope by hand, or keeping the knobs tightened and moving the telescope using the slow-motion cables.

EQ-13 Mount's Load Capacity

The Orion EQ-13 Equatorial Mount has a load capacity of 13 lbs. That means it can typically support a telescope tube and its accessories weighing up to 13 lbs. The amount of weight the mount can stably support will depend somewhat on the type of telescope, however. For instance, compact telescopes such as Maksutov-Cassegrains have short tubes without much "lever arm," so they are quite stable on the mount. Longer telescopes, such as some refractors and Newtonian reflectors have more of a lever arm and thus may wiggle or vibrate for longer when touched.

One-Year Limited Warranty

This Orion product is warranted against defects in materials or workmanship for a period of one year from the date of purchase. This warranty is for the benefit of the original retail purchaser only. During this warranty period Orion Telescopes & Binoculars will repair or replace, at Orion's option, any warranted instrument that proves to be defective, provided it is returned postage paid. Proof of purchase (such as a copy of the original receipt) is required. This warranty is only valid in the country of purchase.

This warranty does not apply if, in Orion's judgment, the instrument has been abused, mishandled, or modified, nor does it apply to normal wear and tear. This warranty gives you specific legal rights. It is not intended to remove or restrict your other legal rights under applicable local consumer law; your state or national statutory consumer rights governing the sale of consumer goods remain fully applicable.

For further warranty information, please visit www.OrionTelescopes.com/warranty.



Corporate Offices: 89 Hangar Way, Watsonville CA 95076 - USA
Toll Free USA & Canada: (800) 447-1001
International: +1(831) 763-7000
Customer Support: support@telescope.com

Copyright © 2022 Orion® Telescopes & Binoculars. All Rights Reserved. No part of this product instruction or any of its contents may be reproduced, copied, modified or adapted, without the prior written consent of Orion® Telescopes & Binoculars.